

BM40 z 1 do 7 sekcji

BM40 from 1 to 7 levers

Charakterystyki ogólne / Technical characteristics		
	l/min GPM	
• Wydatek nominalny / Nominal flow	35	9
• Wydatek maksymalny / Max flow	45	12
	bar PSI	
• Ciśnienie nominalne / Nominal pressure	250	3600
• Ciśnienie max na odbiornikach / Max pressure on ports	320	4700
• Max ciśnienie na powrocie / Max pressure in tank-line	80	1100

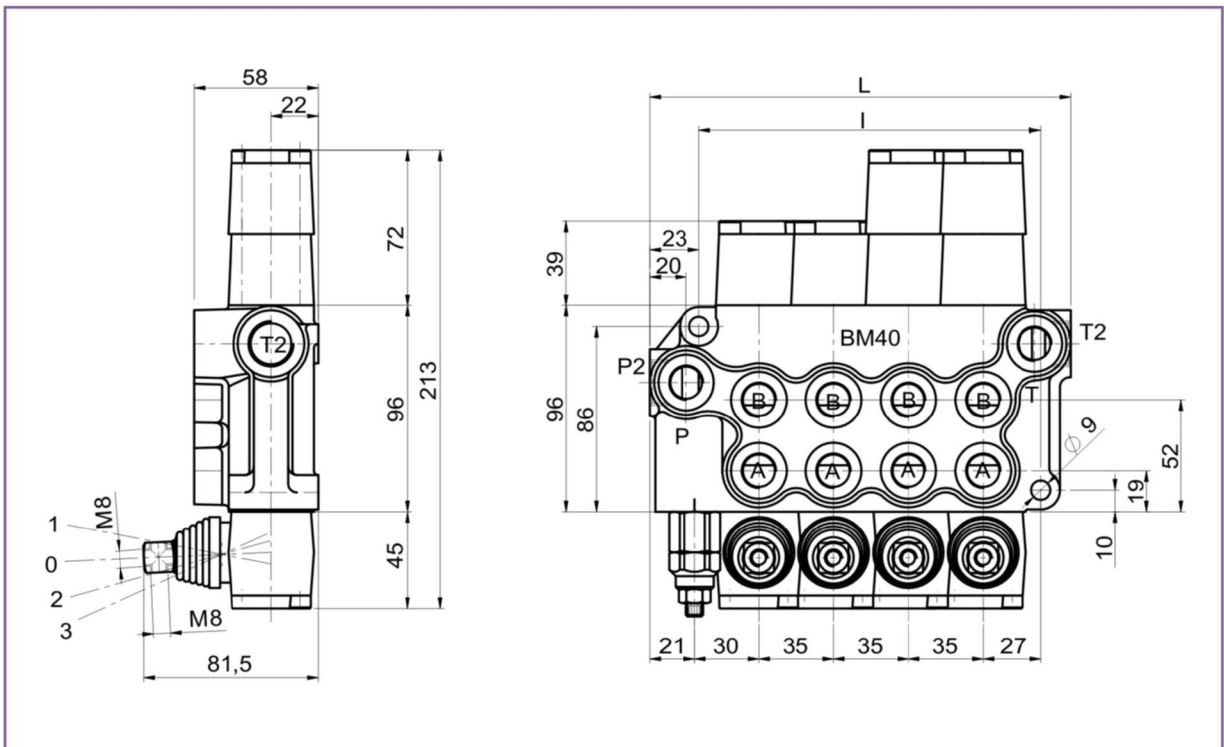
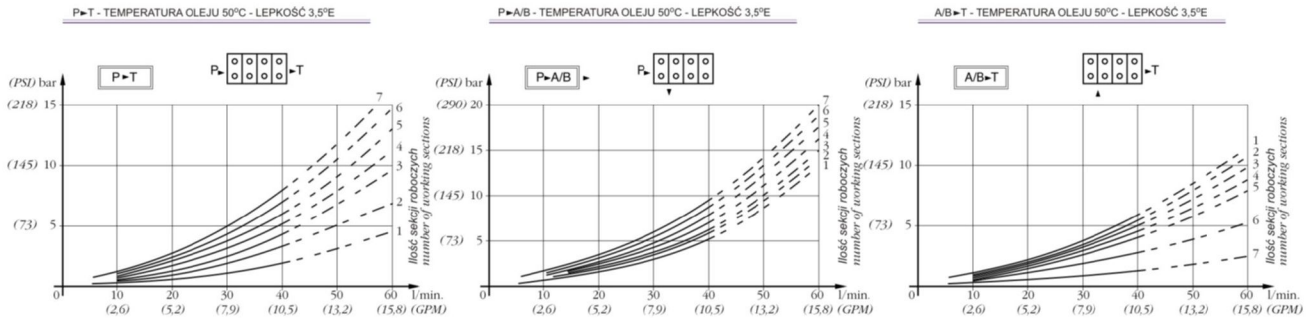
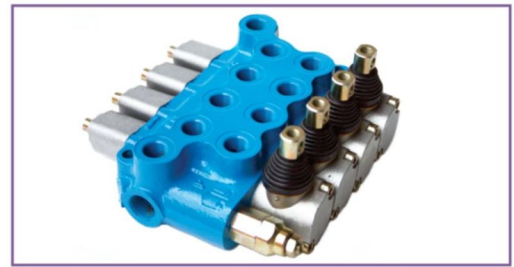

MOD	L	l	Kg
BM40/1	90	55	2,5
BM40/2	125	90	3,7
BM40/3	160	125	5
BM40/4	195	160	6,2
BM40/5	230	195	7,4
BM40/6	265	230	8,6
BM40/7	300	265	9,8

GWINTY STANDARDOWE - STANDARD THREAD					
COD	A-B	P	T	P ₂	T ₂
G	3/8"	3/8"	3/8"	1/2"	1/2"
F	3/4" - 16	3/4" - 16	3/4" - 16	7/8" - 14	7/8" - 14

◀ Na żądanie jest dostępny inny gwint
Other thread available on request

